

GEM™ Trap Secondary Magnetic Filter

GEM Trap Servicing Tool Technical Datasheet

(Patent pending)



EUK | Rev 3 | Nov 2016

GEM Trap Resistance To Debris Build-Up

The GEM Trap is a low maintenance steam trap with no moving parts; it will not wear and its performance is guaranteed on saturated steam for 10 years. The Opal and Emerald GEM Traps are designed for low flow rate applications such as steam line drainage. To minimise service requirements they include a multi-stage filtration system.

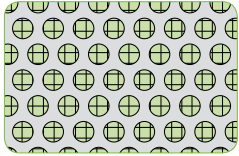

Robust Reinforced Strainer Basket

The Opal and Emerald GEM Traps incorporate a robust reinforced stainless steel mesh strainer basket as the primary means of removing debris. The strainer basket has a large surface area and a mesh size finer than the trap orifice.

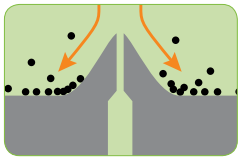

Debris Deflector

All of our low duty traps are designed with an inverted cone technology which deflects micro particles away from the orifice.

An optional extra is our GEM Trap Secondary Magnetic Filter. This magnetic variant of the standard orifice cap can be requested at time of purchase, or retro-fitted to existing Opal and Emerald GEM Traps at your site.

GEM Trap Secondary Magnetic Filter

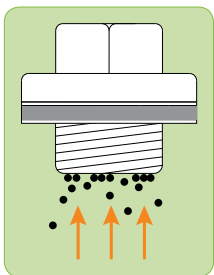

For many steam systems magnetite and other ferrous-ferric oxides are the most prevalent forms of debris, resulting from erosion and oxidation of valves and pipework.

Any magnetic particles that pass through the fine mesh strainer basket will be collected and trapped against the magnet as the condensate flows towards the orifice.

When safely isolated, the magnetic variant of the orifice cap can be inspected whilst the trap remains in-line. Any debris collected can be easily removed from the magnet, and the cap replaced.

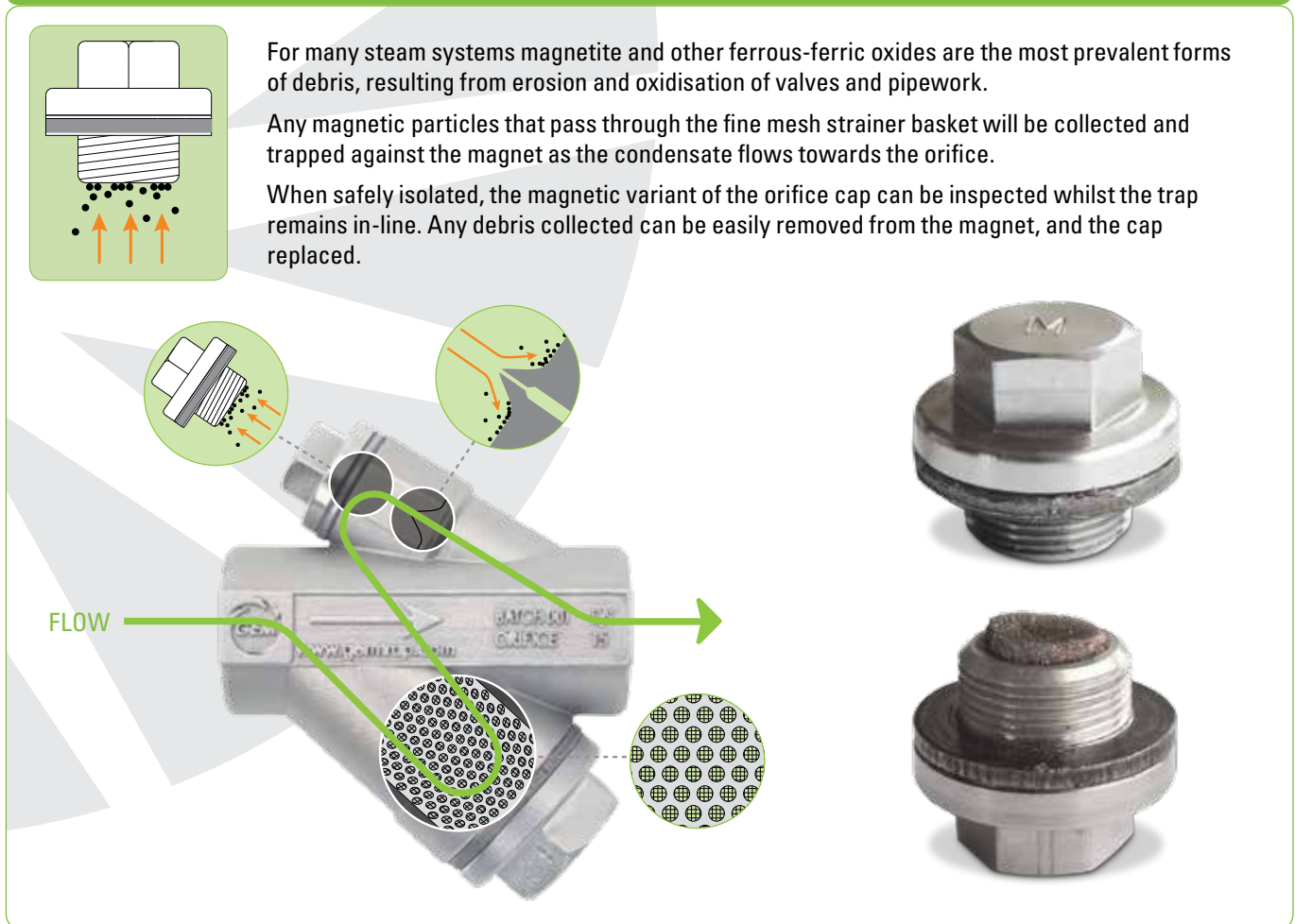

GEM™ Trap Secondary Magnetic Filter

GEM Trap Servicing Tool Technical Datasheet

(Patent pending)



Product drawing

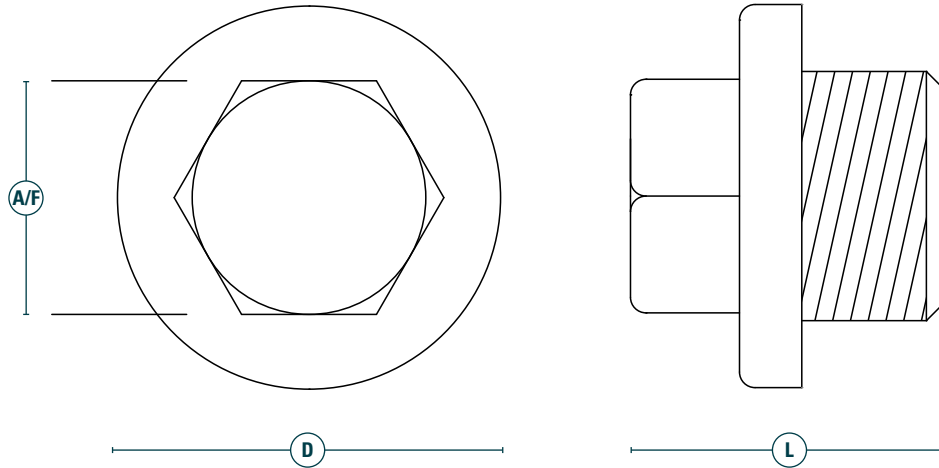

Dimensions and Weights

	Magnetic Filter Cap for Opal GEM Trap	Magnetic Filter Cap for Emerald GEM Trap
Diameter (D)	24.6mm	24.6mm
Length (L)	20mm	24.4mm
Across Flats (A/F)	15mm	15mm
Weight	115g (approx)	115g (approx)

Suitable Applications

- ▶ Opal and Emerald GEM Trap models

Operating Parameters

- ▶ TMA 400°C (750°F)
- ▶ PMA 50 barg (730 psig)

Available Spares

- ▶ Metakamm® 316 Stainless Steel Core / Graphite-faced gasket

Materials

Part	Material
M. Variant Orifice Cap	Stainless Steel ASTM A479 304 / BS EN 10088-3 1.4301
Magnet	TEI High Temperature Magnet
Orifice Cap Gasket	Metakamm® 316 Stainless Steel Core / Graphite-faced

- ▶ Full product traceability is part of our Quality Assurance procedure
- ▶ Type 3.1 material certification to BS EN 10204:2004 (E) are available for all pressure containing parts
- ▶ Thermal Energy reserve the right to amend material specification

All certification/inspection requirements must be stated at time of order placement.

FOR FURTHER INFORMATION

For further information on the full GEM Trap range contact us at enq@thermalenergy.com or visit www.thermalenergy.com